



# USER MANUAL

## DRAGON POWER PLUS

### 3 KVA



# Uninterruptible Power Supply

## Safety precautions

### Operation

1. Before using this product, please read "safety precautions" carefully to ensure correct and safe use, and please keep the manual properly.
2. During operation, please pay attention to all warning signs and operate as required.
3. Do not use the device in direct sunlight, rain or the humid environment.
4. This equipment should not be installed near the heat source area or similar equipment such as electric heater and hot stove.
5. A safe distance and ventilation should be reserved around the UPS. Please refer to the manual for installation.
6. Please use dry cleaning tools for wiping or cleaning the UPS.
7. In case of fire, please use the dry powder extinguisher correctly. There is a risk of electric shock if a liquid fire extinguisher is used.

### Electrical safety

1. The battery life is shortened with the increase of ambient temperature. Regular battery replacement can ensure the UPS to work normally and provide sufficient backup time.
2. Battery maintenance can only be carried out by personnel with battery expertise.
3. There is a risk of electric shock and short circuit in the batteries. To avoid personal injury caused by electric shock, please observe the following warnings when replacing batteries:
  - A. Do not wear watches, rings or similar metal objects;
  - B. Use insulated tools;
  - C. Wear rubber shoes and gloves;
  - D. Do not place metal tools or similar parts on the battery.
4. Please do not expose the battery to the fire for avoiding explosion and endangering the safety of life.
5. Non-professionals should not open or damage the battery, because the electrolyte in the battery contains dangerous substances such as strong acid, which can cause harm to the skin and eyes. If you accidentally touch the electrolyte, immediately wash it with plenty of water and go to the hospital for examination.
6. Please do not short-circuit the positive and negative poles of the battery, which may cause electric shock or fire.

### Use and maintenance

1. The use environment and preservation method have influence on the service life and reliability of this product. Please do not use it in the following working environment:
  - A. High, low temperature and humid places exceeding the technical specifications (temperature 0–40°C, relative humidity 20%–90%).
  - B. Places with vibration and vulnerable to collision.
  - C. Places with metal dust, corrosive substance, salt and combustible gas.
2. If it is not used for a long time, the UPS (without battery) must be stored in a dry environment at the temperature range: –15–60°C. Before starting UPS, the ambient temperature must be warmed to 0°C above and maintained for more than 3 hours.











# Content

1. Introduction .....	1
1.1 Symbol .....	1
1.2 Rear view .....	2
1.3 Specification .....	3
1.4 Electromagnetic compatibility .....	4
2. Installation .....	5
3. Control Panel .....	5
3.1 Panel display .....	6
3.2 Function of button .....	7
3.3 UPS working status table of LCD display .....	8
3.4 Parameter query .....	9
3.5 Function setting .....	10
4. Warning code/fault code and solution .....	13
4.1 Warning code and solution .....	13
4.2 Fault code and solution .....	14
4.3 Common faults and trouble shooting .....	16
5. Control and communication .....	17
5.1 SNMP Card .....	17
5.2 Dry Contact .....	17
5.3 EPO .....	18
6. Battery Maintenance & Repair .....	19

# 1. Introduction

This series of UPS is an online sine wave uninterruptible power supply system with bypass maintenance switch, which can provide reliable and high-quality AC power for your precision equipment. It can be used in a wide range, from computer equipment, communication system to industrial automatic control equipment. Because of its online design, it is different from the backup ups. It continuously adjusts and filters the input voltage. When the power supply is interrupted, it will provide the backup power from the backup battery without time interruption. In case of overload or inverter failure, the UPS switches to the bypass state and be powered by the mains. If the overload is cleared, the UPS will automatically switch back to the inverter power supply state.

## 1.1 Symbol

Symbols and Meanings	
Symbols	Meanings
	Attention
	Danger
	AC (alternating current)
	DC (direct current)
	Protective earth conductor
	Protective connecting conductor
	Loop
	Do not place with sundries
	Overload
	Battery
	ON/OFF Switch

## 1.2 Rear view

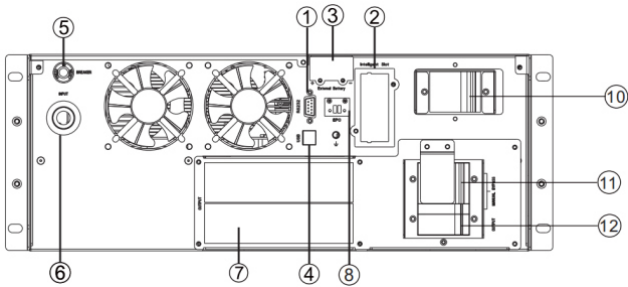

- ① Computer interface
- ② Smart slot (optional)
- ③ External battery connection
- ④ USB
- ⑤ Input over current protection
- ⑥ AC INPUT
- ⑦ Output socket
- ⑧ EPO
- ⑨ Battery interface
- ⑩ Battery breaker (optional)
- ⑪ Maintenance bypass switch (optional)
- ⑫ Output breaker (optional)

## 1.3 Specification

Model	DP10L-3KTRL-120	
Capacity	3kVA/3KW	
Input		
Nominal Voltage	100/110/115/120/127VAC, L+N+PE	
Voltage Range	55-150VAC	
Frequency	40-70Hz	
Power Factor	> 0.99	
THDi	≤4% (linear load); ≤5% (non-linearload)	
Output		
Nominal Voltage	100/110/115/120/127VAC, L+N+PE	
Voltage Regulation	±1%	
Frequency	50/60Hz±0.1%	
Crest Ratio	3:1	
Voltage Harmonic Distortion	≤2% (linear load); ≤4% (non-linear load)	
Transfer Time	Line mode to battery mode,0ms;inverter to bypass,4ms(typical)	
Waveform	Pure sine wave	
Overload time	Line mode: 10 min@102%-110% load 1 min@110-130%load 10s@130%-150%load	Battery mode: 1 min@102%-110% load 10s@110-130%load 30s@130%-150%load
Efficiency		
Line Mode	94%	
Battery Mode	93%	
ECO Mode	98%	
Battery		
Type	Sealed lead acid maintenance free	
Voltage	96VDC	
Battery Number	12V 9Ah*8pcs	
Charging Current	1A	
Charging Mode	Two/Three period charging	
Management		
Intelligent port	RS232 /USBport/SNMP card (optional)/Dry contact kit (optional)	
Environment		
Operation Temperature	0-40°C	
Relative Humidity	0-95%(non-condensing)	
Audible Noise	< 40dB@1 meter	
Altitude	The altitude should not exceed 1000m,and the height above 1000m should be reduced to a maximum of 4000m. Refer to IEC 62040	

Load at high altitude=Rated power \*Derating factor (corresponding to altitude)

Altitude(m)	1000	1500	2000	2500	3000	3500	4000	4500	5000
Derating factor	100%	95%	91%	86%	82%	78%	74%	70%	67%

⚠ Notice: If the machine is used at above 1000m, diminishing ratings output must be used, please refer to above table for derating factor.

## 1.4 Electromagnetic compatibility

<b>Safety</b>	
IEC/EN 62040-1-1	
<b>EMI</b>	
Conducted Emission.....IEC/EN 62040-2	Class A
Radiated Emission.....IEC/EN 62040-2	Class A
<b>EMS</b>	
ESD..... IEC/EN 6100-4-2	Level 4
RS .....IEC/EN 6100-4-3	Level 3
EFT ..... IEC/EN 6100-4-4	Level 4
SURGE.....IEC/EN 6100-4-5	Level 4
Low Frequency Signals.....IEC/EN 6100-2-2	
<b>Warning:</b> This is a product for commercial and industrial application in the second environment–installation restriction or additional measures may be needed to prevent disturbances.	

### NOTICE

This is a product for restricted sales distribution to informed partners. Installation restrictions or additional measures may be needed to prevent radio interference.

Operate the UPS in an indoor environment only in an ambient temperature range of 0–40°C (32–104°F). Install it in a clean environment, free from moisture, flammable liquids, gases and corrosive substance.

This UPS contains no user-serviceable parts except the internal battery pack. The UPS ON/OFF push buttons do not electrically isolate internal parts. Under no circumstance attempt to gain access internally, due to the risk of electric shock or burn.

Do not continue to use the UPS if the panel indications are not accordance with these operating instructions or the UPS performance alters in use. Reflect all faults to your dealer.

Servicing of batteries should be performed or supervised by personnel knowledgeable of batteries and the precautions.

Keep unauthorized personnel away from the batteries. Proper disposal of batteries is required. Refer to your local laws and regulations for disposal requirement.

**DONOTCONNECT** equipment that could overload the UPS or demand DC current from the UPS, for example: electric drills, vacuum cleaners, laser printers, hair dryer or any appliance using half-wave rectification.

Storing magnetic media on top of the UPS may result in data loss or corruption.

Turn off and isolate the UPS before cleaning it. Use only a dry cloth, never liquid or aerosol cleaners.

## 2. Installation

### 2.1 Setup the UPS

#### Step 1: UPS input connection

Plug the UPS into a two-pole, three-wire, grounded receptacle only. Avoid using extension cords.

#### Step 2: UPS output connection

For socket-type outputs, simply connect devices to the outlets. For terminal-type input or outputs, please follow below steps for the wiring configuration:

- Remove the small cover of the terminal block.
- Suggest using AWG14 or 2.1mm<sup>2</sup> power cords.
- Upon completion of the wiring configuration, please check whether the wires are securely affixed.
- Put the small cover back to the rear panel.

#### Step 3: Communication connection

Communication port:



To allow for unattended UPS shutdown/start-up and status monitoring, connect the communication cable one end to the USB/RS232 port and the other to the communication port of your PC. With the monitoring software installed, you can schedule UPS shutdown/start-up and monitor UPS status through PC.

The UPS is equipped with intelligent slot perfect for either SNMP or AS400 card. When installing either SNMP or AS400 card in the UPS, it will provide advanced communication and monitoring options.

**PS. USB port and RS-232 port can work at the same time.**

#### Step 4: Turn on the UPS

Press the ON combination buttons on the front panel for two seconds to power on the UPS.

Note: The battery charges fully during the first five hours of normal operation. Do not expect full battery run capability during this initial charge period.

#### Step 5: External battery connection

This UPS does not include batteries.

Please connect external batteries as the below drawing.

RS232 interface on UPS:

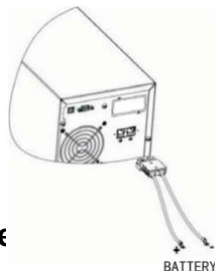
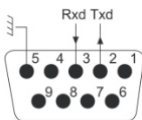

## 3. Control Panel





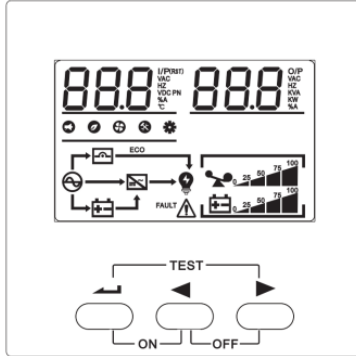











### 3.1 Panel display







Display	Function
<b>Error message</b>	
<b>FAULT</b>	Failure occurred
<b>△</b>	Warnings
<b>88</b>	Fault code
<b>Mute</b>	
	Mute function
<b>Input and output voltage, DC voltage, UPS internal temperature</b>	
<b>888</b> <sub>V<sub>IN</sub></sub>	VAC: input and output voltage; VDC: DC voltage °C: UPS internal temperature; Hz: Frequency
<b>Load information</b>	
	The load volume(0–25%, 26%–50%, 51%–75%, 76%–100%) is shown here, and the overload icon flashes when the battery is low or not connected
<b>Battery information</b>	
	The battery capacity(0–25%, 26%–50%, 51%–75%, 76%–100%) is displayed separately, and the battery icon flashes when the battery is low or not connected
<b>Other information</b>	
	AC
	Battery
	Bypass
	Inverter
	Output working
	Fan status: LED will always be on when the fan is normal, and flashes when the fan fails
	Setting icon: when entering the setting menu, the icon will light up, and the icon is not shown in the other cases
	ECO function: the icon light up when ECO function is used, otherwise the icon is not displayed
	Maintenance icon: when the maintenance switch is turned on, the icon lights up, in the other cases, the icon is not displayed

### 3.2 Function of button

Button	Functional Description
Combo key for <b>turning on</b> the UPS (  +  )	<p><b>AC Mode:</b> press the two buttons at the same time for 1 second above to start UPS.</p> <p><b>Battery Mode:</b> please press (  ) confirmation button first, after turning on the screen, please press the two buttons at the same time for 1 second above to start UPS.</p>
Combo key for <b>turning off</b> the UPS (  +  )	<p><b>AC Mode:</b> press the two buttons at the same time for 1 second above to turn off the inverter, the system will turn to Bypass Mode.</p> <p><b>Battery Mode:</b> press the two buttons at the same time for 1 second above to turn off the inverter, and after 1 minute, the system will shut down, and the screen will turn off.</p>
Combo key for self-checking and mute function (  +  )	<p><b>Testing:</b> in AC Mode, press the two buttons at the same time for 2 seconds above to test the battery.</p> <p><b>Mute:</b> in Battery Mode/Alarm/Testing Mode, press two buttons at the same time for 2 seconds above to erase alarms, press two buttons again for 2 seconds above to recover alarms.</p>
Function setting/confirmation key (  )	<p><b>Function setting:</b> press the key more than 2 seconds to enter the function setting page, after completing the setting, press the key more than 2 seconds again to return to the main page.</p> <p><b>Confirmation:</b> in the function setting page, press the confirmation key 1 to 2 seconds to confirm the setting options.</p>
Page turning/query key (  ,  )	<p><b>Page turning:</b> press  or  key 1 to 2 seconds to turn to left or right page.</p> <p><b>Polling Mode:</b> press the  key more than 2 seconds to enter Polling Mode, circularly display each page content for 2 seconds, press  more than 2 seconds again to return to the main page.</p>





### 3.3 UPS working status table of LCDdisplay

ACMode	
LCDdisplay content	Instruction
	<p>UPS can provide stable AC output when AC input in the permissible range. In AC Mode, batteries will also be charged by the UPS.</p>
Battery Mode	
LCDdisplay content	Instruction
	<p>When the AC input is out of limited range or shut off, the UPS will turn to Battery Mode. The batteries supply the inverter and have beep every 4 seconds.</p>
Bypass Mode	
LCDdisplay content	Instruction
	<p>When the AC input keeps normal, start the bypass mode and close the UPS on the panel. The UPS will turn to Bypass Mode, and have beep every 2 minutes.</p>
Error Condition	
LCDdisplay content	Instruction
	<p>When the UPS has faults or alarms, LCD display will show the information.</p>

### 3.4 Parameter query

Normally the LCD display can show 8 pages totally. Pressing the query button ◀ or ▶ for 0.1–2sec can enter into the different pages which show all information, such as input, battery, output, load, software version, temperature, and etc. If alarms occur, the display will add one more page to show the alarm information. If the UPS has faults, the default display will turn to the Fault code page automatically, the home page will show the fault or alarm information by default. When UPS keeps normal working, the home page default display will show the output voltage and frequency information.

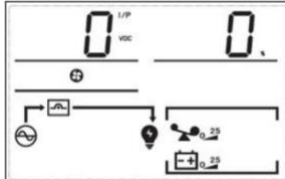
Press ▶ (right button) more than 2 sec, LCD will turn to the polling mode. Every 2 sec the shown display will turn pages. Press ▶ long time, LCD will exit the polling mode.

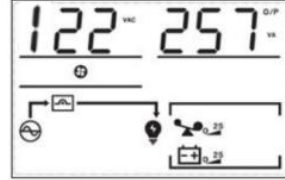
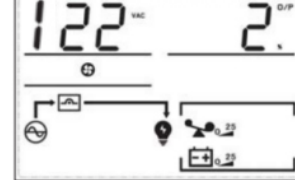
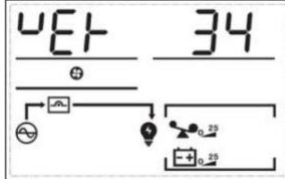
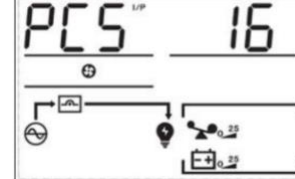
LCDDisplay 1: UPS input & output voltage	LCDDisplay 2: UPS input & output frequency
	
LCDDisplay 3: Battery voltage and capacity	LCDDisplay 4: Output voltage and output active power
	
LCDDisplay 5: Output voltage and output apparent power	LCDDisplay 6: Output voltage and load percentage
	
LCDDisplay 7: UPS system software version	LCDDisplay 8: connected battery quantity
	

### 3.5 Function setting

#### ●01: Output voltage



LCD Display	Setting
	<ol style="list-style-type: none"> <li>1. Press the function setting button (↵) over 2 sec, then go to the setting page. Press the page turning buttons till the setting page of output voltage, and the word "OPU" flashing.</li> <li>2. Press confirmation button (↵) 0.5–2sec, then go to the setting page of output voltage <b>OPU</b>. The "OPU" words light on, and the numbers by left side of <b>OPU</b> keeps flashing. Press page turning buttons (◀) or (▶) 0.5–2sec to choose different output voltage value, the optional voltage values are 110V, 115V, 120V and 127V. The default output voltage is 120V. Please save after setting.</li> <li>3. Turn to the voltage value which you need, and press confirmation button (↵) 0.5–2sec, then finish the <b>OPU</b> setting. The number by left side of <b>OPU</b> will keep lighting on, no flashing.</li> <li>4. Press functional setting button (↵) over 2 sec, quit the setting page and back to the home page. (Or no operation, waiting more than 30 sec, the page will come back to home page automatically).</li> </ol> <p>Note: When the output voltage setting with 110V, the output needs to decrease to 90% of rated power.</p>

#### ●02: Other functional setting



##### 02-1: Expert Mode (EP)

LCD Display	Setting
	<p>The expert mode setting with ON, then go to the functional setting page again. The functional setting will show battery QTY (PCS), EPO, charging current and other items can be selected. When the expert mode setting with OFF, functional setting page will show only the general options.</p> <p>Note: The expert mode default to OFF. When setting as ON then re-connected the AC power, the EP can be recovered as OFF.</p>



## 02-2 Battery low voltage shutdown point/End of discharge voltage(EOD)

LCD Display	Setting
 	<p>The options of EOD setting are <b>dEF</b>, 9.8V, 9.9V, 10V, 10.2V, 10.5V. By default, the EOD is <b>dEF</b></p> <p>(The EOD will be changed according to loading condition.            10.5V@load &lt; 25% , 10.2V@25% &lt; load &lt; 50% , 10V@load &gt; 50%).</p>

## 02-3: Economic Operation Mode

LCD Display	Setting
 	<p>ECO is OFF by default, can be set as <b>ON</b> to improve the efficiency of system operation.</p> <p>Note: For the models with PF &lt; 1, <b>OFF</b> by default, and unable to set.</p>

## 02-4: Emergency shut down(EPO)

LCD Display	Setting
 	<p>When <b>EP</b> is set to ON, the <b>EPO</b> option appears on the function setting page. Emergency shutdown can be set as closed or open to trigger, the default is open to trigger.</p> <p>Note: After EPO action, emergency shutdown, close all outputs immediately.</p>

### 02-5:Battery quantity(PCS)

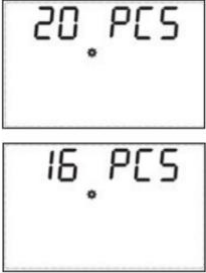
LCD Display	Setting
	<p>When EP is set to ON, the <b>PCS</b> option appears on the function setting page, will enter the password page, enter the password (the general password is 135), you can set the number of batteries. The default battery number is 16pcs, which can be set to 16/18/20pcs.</p>

### 02-6:Charger Current(CHG)

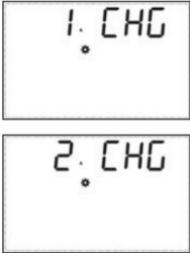
LCD Display	Setting
	<p>When EP is set to ON, the <b>CHG</b> option appears on the functional setting page, the charging current can be set, 1-12A optional, default 1A. Noted: if UPS built-in batteries, the charger current default 1A, and can't be changed.</p>

### 02-7:Input Neutral and Live cable reverse alarm function

LCD Display	Setting
	<p>The input neutral and live cable reverse alarm mode is closed by default, can choose to open to improve the safety of the system. Note: Factory settings default closed, please open if you need.</p>

## 4. Warning code/fault code and solution

### 4.1 Warning code and solution

When the "△" symbol on the UPS LCD flashes, the UPS is in alarm state. Press the page turning key to the error state page (refer to 3.5), observe the alarm code and make appropriate processing according to the table below.

Alarm	Indication	Possible reasons	Treatment measures
1	No battery connection	1. No battery connected 2. Battery damaged	1. Check the connection of batteries. 2. Change the batteries.
2	Battery low voltage	The battery voltage is less than the low voltage warning point. The batteries discharge to below the alarm point.	After the battery has been sat for a period of time, it can be turned on again. The built-in charger can be turned on to charge the battery.
4	Input neutral and live cables are reversed	1. Input neutral and live cables are reversed. 2. Input ground cable is not connected. 3. Output ground cable is not connected.	1. Reverse the neutral and the live cables. 2. Check the ground cable connection.
8	Battery over voltage	UPS detects high battery voltage	Check that the battery quantity setting is consistent with the actual battery quantity.
9	Charger failure	Abnormal charger hardware	Contact the supplier.
10	Over temperature alarm	1. Fan fault 2. Air duct of UPS rear panel is blocked. 3. Overload 4. NTC sensor abnormal or connection abnormal 5. Power component IGBT is damaged.	1. Check the rectifier fan. 2. Remove blockages on the rear panel of the UPS. 3. Check the load. 4. If the above treatments do not work, contact the supplier.
12	Fan fault	1. Fan wiring is loose. 2. Fan hardware abnormal	Check the fan and connection
13	AC fuse open	Fuse blown	Contact the supplier.
14	EEPROM fault	EEPROM chip damages.	Contact the supplier.
21	Overload	The loads exceed the rated power.	Check the load.
22	3 times consecutive overload locks	3 times consecutive overload locks	Shut down and restart UPS.
23	EPO action	Press EPO button.	1. Release EPO button. 2. Check the wiring harness on EPO button.
24	Maintenance switch action	The maintenance switch is pressed.	Release maintenance switch.





## 4.2 Fault code and solution

When the "FAULT" is long bright, and "△" symbol on the UPS LCD flashes, the UPS is in fault state. UPS automatically switches to the error status page (refer to 3.5) to observe the fault code and make appropriate processing according to the following table.

Fault code	Indication	Possible reasons	Treatment measures
1	Bus boosting soft-starting fail	1. AC abnormal 2. Abnormal soft-starting circuit of bus	Check the mains, if all normal, please contact the supplier.
2	Bus over voltage	1. AC abnormal 2. Software processing error 3. Bus capacitor failure	Check the mains, if all normal, please contact the supplier.
3	Bus under voltage	1. City electricity is too low. 2. Software processing errors 3. Bus capacitor failure	1. Please check the rectifier fan. 2. Clean the obstacles on the air duct of the rear panel of the UPS. 3. Check the loads. 4. If all of above do not work, please contact the supplier.
7	Over temperature	1. Fan failure 2. The air duct on the rear panel of the UPS is blocked; 3. Overload 4. NTC sensor abnormality or abnormal wiring 5. Power component IGBT is damaged.	1. Please check the rectifier fan; 2. Clean the obstacles on the air duct of the rear panel of the UPS; 3. Check the loads; 4. If all of above do not work, please contact the supplier.
8	Battery relay short circuit	Relay RL1/RL3 hardware damaged	Please contact the supplier
9	Bus relay soft-starting fail	1. City electricity abnormal 2. Bus soft-starting circuit abnormal	Please check the city electricity power, if no abnormal, please contact the supplier.
17	Inv soft-starting fail	1. Some hardware of the inverter is damaged; 2. The control panel fails.	Please contact the supplier.
18	Inv output over voltage	1. Some hardware of the inverter is damaged; 2. The control panel fail.	Please contact the supplier.
19	Inv output under voltage	1. Some hardware of the inverter is damaged; 2. The control panel fails.	Please contact the supplier.
20	Inv short circuit	1. Some hardware of the inverter is damaged. 2. Output short circuit	1. Check if the short circuit exists on the output of UPS. 2. Check if the load is short circuit. 3. If no abnormal, please contact the supplier.

26	Negative power protection(output with AC input fail)	1. Bypass reverses to the inverter. 2. load abnormal	Check the loads and if no abnormal, please contact the supplier.
33	Inv relay or SCR open circuit	Relay RL8 is damaged.	Please contact the supplier.
34	Inv relay or SCR short circuit		
35	Bypass relay or SCR open circuit	Relay RL4/RL6 is damaged.	Please contact the supplier.
36	Bypass relay or SCR short circuit		
37	I/O connection reversed	Reverse wiring on input and output.	Please check the wiring harness of input and output.
39	Charger short circuit	1. Output of charger short circuit 2. Charger hardware abnormal	Please contact the supplier.
66	Over load fault	1. Overload too much 2. The voltage reduction causes the system rated power to decrease.	1. Check if the load is within the specified range; 2. Check if the voltage has been reduced.
67	Charging over voltage or battery connection reversed	1. Hardware error 2. Number of battery wrong; 3. Wiring wrong.	1. Check whether the battery wiring or battery number meets the requirements. 2. If no any abnormal, please contact the supplier.
68	Unknown machine model	Software version error	1. Restart the machine; 2. If no any abnormal, please contact the supplier.
72	Charger over current	1. Hardware error; 2. Battery abnormal.	1. Check whether the battery wiring or battery number meets the requirements; 2. If no any abnormal, please contact the supplier.
73	No bootstrap	Software version error	1. Restart the machine; 2. If no any abnormal, please contact the supplier.
81	Unknown battery QTY setting	Number of battery wrong	1. Check whether the battery number meets the requirement; 2. Check if the configuration of the battery jumper cap is the same as the software setting.
82	Battery QTY setting matching error	Number of battery setting wrong and can not be matched with software setting.	

### 4.3 Common faults and trouble shooting

Number	Problem or errors description	Reason	Solution
1	Connect to city electricity, and no display on LCD display panel	No input power	Check if the input wiring harness of UPS is in well connection.
		Input voltage under voltage or overload	Use voltage meter to check the input voltage if in normal or meets the requirement.
2	City electricity in normal, no AC input indication, UPS is still working in battery mode	UPS power switch is still off	Press UPS city electricity power button on
		The wiring harness is loosen or in poor connection.	Check the input wiring harness whether in normal.
3	UPS not display error, but no output voltage	The wiring harness is loosen or in poor connection	Make sure the wiring harness in well connection.
4	Press  button, UPS doesn't start	Press button too shortly	Press  over 5 seconds, hear "Di" sound
		Overload	Remove all loads and restart the machine.
5	With city electricity, but no city electricity indication	Mains voltage or frequency over UPS input range	Use a multi-meter to check whether the input voltage and the input frequency meets the requirements.
6	The battery discharge time is lower than the standard time	The power of batteries has been used.	Change new battery
		The batteries were not be charged fully.	Charge the batteries more than 8 hours under normal city electricity, then retest it.
7	Abnormal sound or smell come out from the inside of UPS	Inner of UPS may be damaged	Please immediately turn off the UPS, cut off the power input and contact the customer service center for technical support.
8	Battery mode display yellow light, long buzzer sounds, battery capacity is insufficient, ready to shut down	The power of battery is low, UPS is ready to shut down, and the loads will be cut off.	1. Save the data on the loads immediately and complete shutdown the important loads to avoid data loss or damage. 2. Immediately connect the UPS input terminal to the standby AC power supply.

## 5. Control and communication

UPS includes several communication ports: RS232, EPO, SNMP card, USB, and dry contact card.  
**NOTICE: Only one of SNMP card, and dry contact card can be used at the same time. Only one of RS232 and USB is available at the same time.**

### 5.1 SNMP Card

SNMP card is used to monitor the UPS via TCP/IP protocol, users can check the UPS status and data online. Please refer to the user manual of SNMP card to get more detailed information.

### 5.2 Dry Contact

There are two types of dry contact for option: DB9, phoenix terminal.

Maximum output current for dry contact is 1A. The function of dry contact is listed as below:

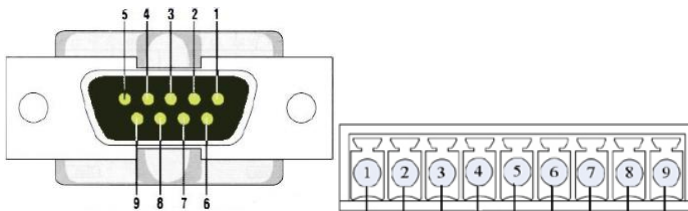

DB9 port

phoenix terminal

Function	DB9	Phoenix	Description
UPS fault	1	9	Open from common connection: UPS is abnormal. Closed: UPS is normal.
General	2	7	Open from common connection: UPS is warning Closed: UPS is normal.
GND	3	2	Internal GND, used to connect external power supply 12-24Vdc
Remoted shutdown	4	4	Input port. Used with external power supply. If connected to power supply, UPS transfer to bypass. UPS shutdown if bypass is abnormal.
Common connection	5	1	Common connection of output signal. Connected to power supply for input signal.
Bypass mode	6	8	Closed to common connection: UPS is working in bypass mode. Open: UPS is not working in bypass mode.
Battery low	7	6	Open from common connection: battery low alarm Closed: battery capacity is normal or not in battery mode
Normal mode	8	5	Closed from common connection: UPS is working in normal mode.
Utility failure	9	3	Open form common connection: utility input fails.

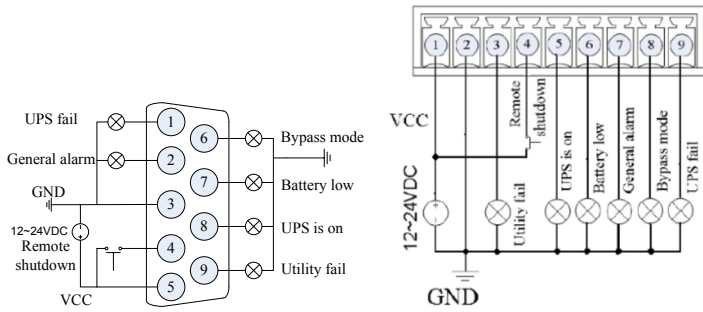

### 5.3 EPO

The remote EPO is located on the rear panel of UPS. Its normal closed, if its open, it will active EPO function, the UPS will shutdown output.

## 6. Battery Maintenance & Repair

- This series of UPS only needs very little maintenance. The batteries of the standard machine are seal type and no need to maintain frequently. But also keep charging to get the expected battery life. UPS keeps charging when it is connecting to AC, no matter on/off. And if also have function of overcharging and overload protection.
- If you do not use UPS for a long time, you should charge the UPS every 4–6 months. In the area of high temperature, battery should be charging and discharging every two months, the charging time should not be less than 12 hours.
- In normal circumstances, service life of the battery is 3–5 years, if the battery is found to be in poor condition, it must be replaced in advance. When replacing the battery, it must be done by a professional.
- When replacing the battery, follow the principle of quantity and model consistent.
- The battery should not be replaced individually and when it replaced as a whole should be according to the battery suppliers instructions.
- In normal circumstances (under the condition of UPS with little back up power), the battery should be charged and discharged every 4–6 months. Keep discharging before UPS shut down then keep charging. The standard machine charging time should not be less than 12 hours.

**Product are subject to change without notice.**



**Español**



**English**

**[www.lbspower.com](http://www.lbspower.com)**